



i - intelligence

i - innovation

i - integration

Rules and recommendations on the visual style of the company.

Brand Guidelines



Contents:

About the company	5
Logo	7
Typography	15
Color palette	18
Brand icons	22
Devices and their proportions	24
Corporate identity materials	27



-
- About the company
 - Product
 - Mission
 - Vision
 - Brand writing and domain names

About the company

10



About the company

i3 — is a Ukrainian company specializing in the development and implementation of modern management systems for "smart homes" and commercial properties. We offer comprehensive process optimization and solutions that include equipment and software created with the latest technologies.

Our solutions provide comfort for a large community of users.

Our product

The main product of i3 is a universal platform for smart solutions, including:

Devices: high-quality devices for system integration.

Software: a user-friendly interface for configuring and managing all components.

Mobile applications: for easy control anytime and anywhere.

Mission

Our mission — to make intelligent management accessible, simple, and effective for everyone, ensuring comfort, safety, and energy efficiency in living and working spaces.

Vision

We strive to become a leader in process modernization in Ukraine and on the international market by creating innovative products that redefine the concept of comfortable living.



Rules for brand writing

Correct writing:

Company name: **i3**

Main device line: **i3 Atom**

Additional device line: **i3 Atom Extension**

Mobile application: **i3 Home**

Use in social media

Social media profiles used for official publications on behalf of i3 cannot be created without approval from the marketing department.

The following hashtags must be used in social media for various content related to **i3** : **#i3, #i3_system, #i3_smart_home, #my_za_droty.**

Displaying partnership status with i3 on your website or placing the company logo is only allowed with the company's permission.

Domain names

Use in domain names

A domain name is a very important marketing tool that should bring clients to you and ensure brand visibility. A well-created domain boosts search rankings, the company's image, and differentiates it from millions of other web projects.

To use «**i3**» in a URL address, it must be part of the URL path.

✓ **mycompany.com/i3.systems/**

It is prohibited to register domains or subdomains containing the name of i3 Engineering or its products. It is also forbidden to register similar names that might confuse clients.

✗ **i3.systems.mycompany.com**
support-i3systems.com
i3companyua.org



- Logo
- Symbol
- Logo construction
- Logo variants
- Protective space
- Logo usage
- Logo + slogan, partnership

Logo

20



Logo

Our logo — is an authentic graphic symbol used to identify the brand.

It is important to maintain the original appearance of the logo, preserving all proportions, colors, and graphic solutions across all media where the company's logo is used.

App logo:

Consists of the company symbol on a black or white background. The symbol on the icon should be slightly shifted to the left for better visual perception of the composition.

Important! These are the only allowed variants of the app logo usage. Any modifications are prohibited.

Follow the provided logo image variants on light and dark tones, maintaining the readability of all logo elements.

Main logo versions:



App icon





Symbol

The logo is a stylized graphic depiction of three "I" letters combined with the company name.

i - intelligence, i - innovation, i - integration.

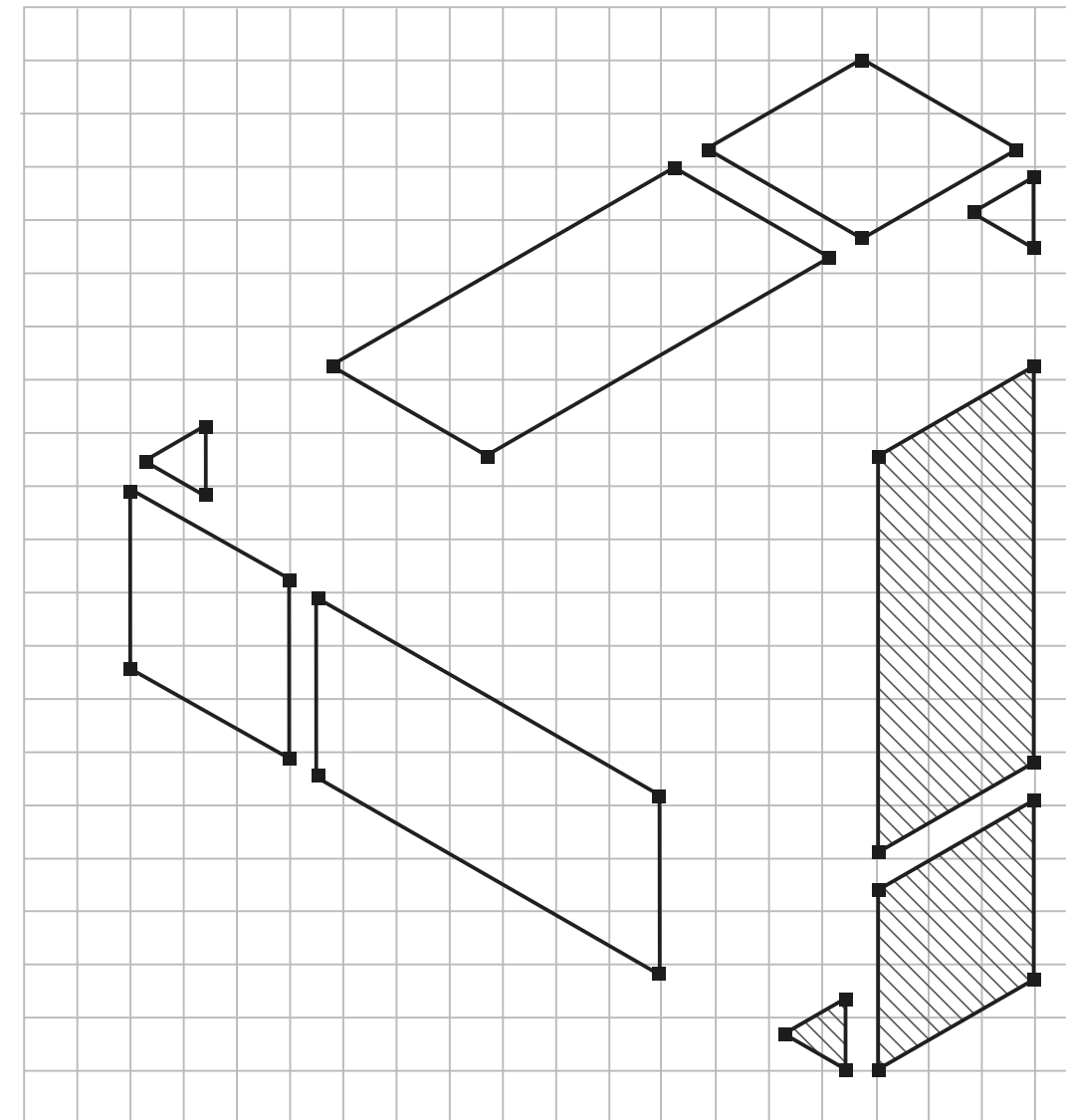
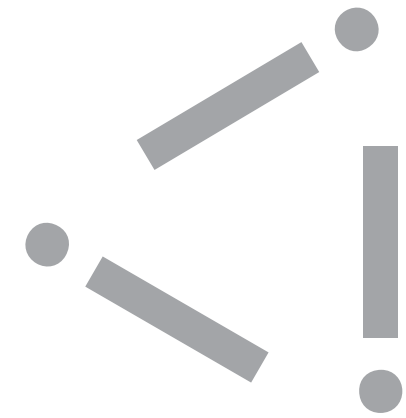



Logo construction

Our logo has a modern and stylish appearance with harmonious proportions that convey a sense of reliability and professionalism. It is important to strictly adhere to the logo's proportions when using it and never alter them in any way.

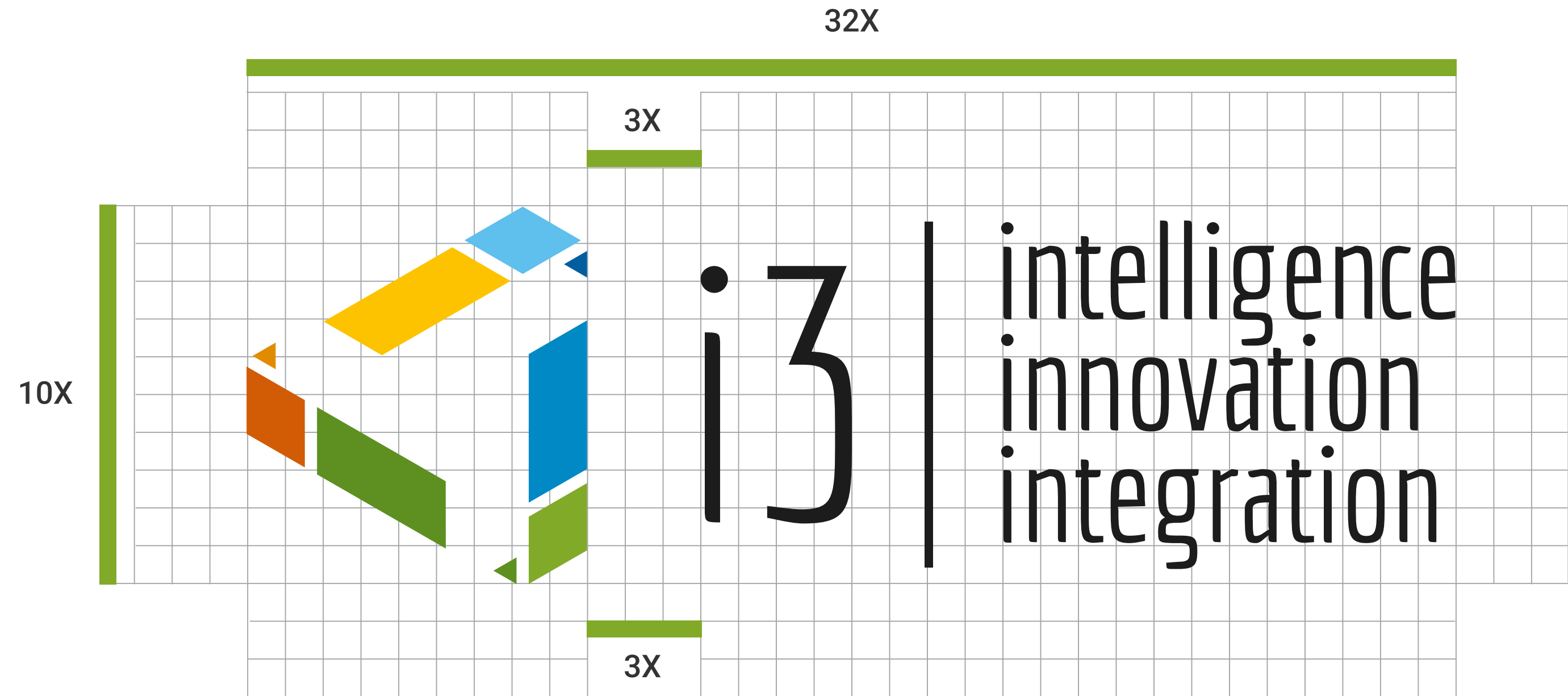



Logo variants

To maintain brand recognition, strive to use the **main logo** whenever possible. However, in cases where this is not feasible, you may use the following logo variations:

- **A shortened version of the logo**
- **The symbol**
- **A footer logo** (minimum allowable proportions for the footer logo: 8.5x5mm)

Main logo



A shortened version of the logo



The symbol



A footer logo

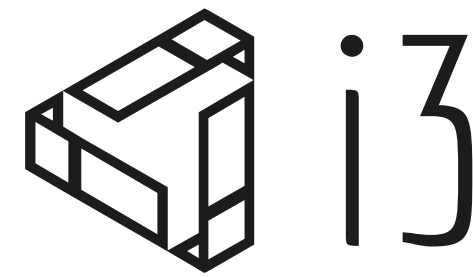



Protective space

When using the i3 logo and symbol, leave enough space around them.

To ensure readability, leave space equivalent to the width of two stylized "I" letters to maintain visual clarity.

This helps create a clean and neat appearance, allowing the symbol and logo to stand out effectively. Providing sufficient space improves visibility and strengthens brand identity.

The protective field is conditional and does not appear on graphic media.

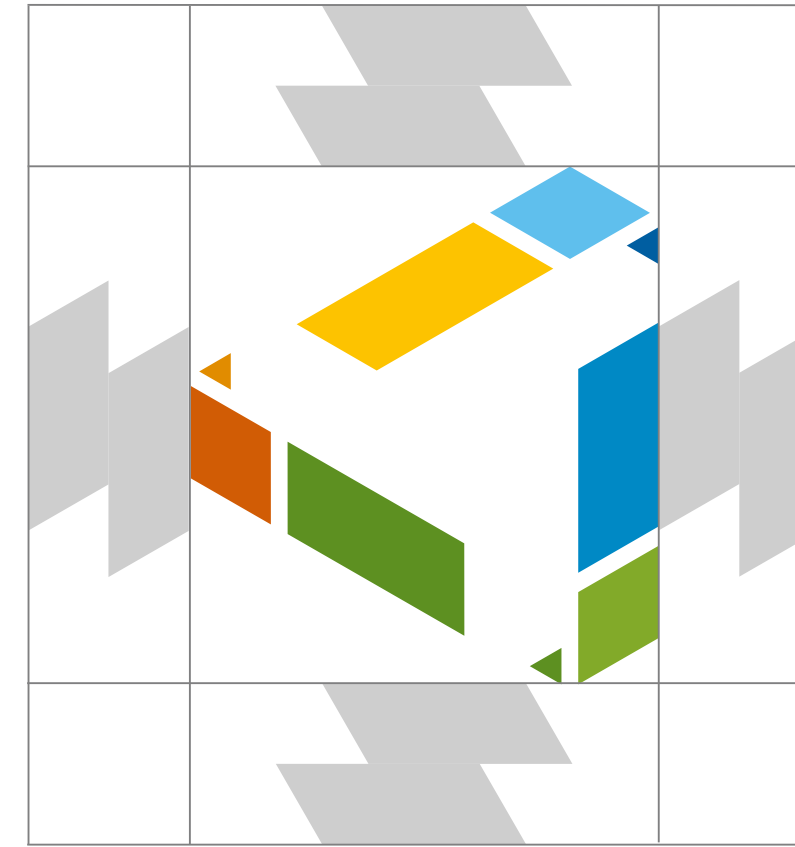



Logo usage:

Allowed logo images:

On light backgrounds, the company name should be black or in a color that ensures optimal readability.

On dark backgrounds, the company name can be white or in color.

On photographic backgrounds, it is recommended to use the white, black, or contrasting version for better readability.

If necessary, black-and-white versions of the logo may be used.

Prohibited logo modifications:

Avoid actions that may compromise the integrity of the logo. Adhering to branding guidelines is key to maintaining and supporting our unique identity.

The logo must remain unchanged in structure, color, proportions, elements, and orientation, demonstrating its consistent design.

Allowed stylistic uses of the logo:



Unacceptable stylistic uses of the logo

Do not change composition and proportions.



Do not alter the color of the logo.



Do not use shadows or glow effects.



Do not distort or tilt the logo.



Do not use an outline for the logo.

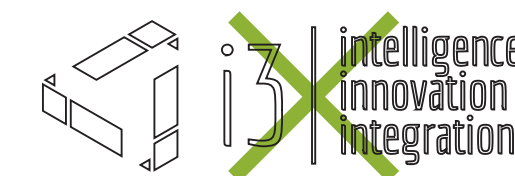

Do not add external graphic elements to the logo.





Logo + slogan, partnership

Logo + Slogan: Sometimes, to enhance marketing communication, it is permissible to use the following slogans next to our logo.

Combining two partner logos:

- It is recommended to use a co-branded logo to emphasize the partnership with i3, e.g., in visual materials for joint marketing purposes, printed products, web banners, etc.

- Select one of the proposed co-branded logo templates. Consider the background (dark or light) where the logo will be used, the proportions of the partner logo, and only then choose the most suitable template.

Important! Use only the proposed templates for combining two partner logos.

Company slogan versions:

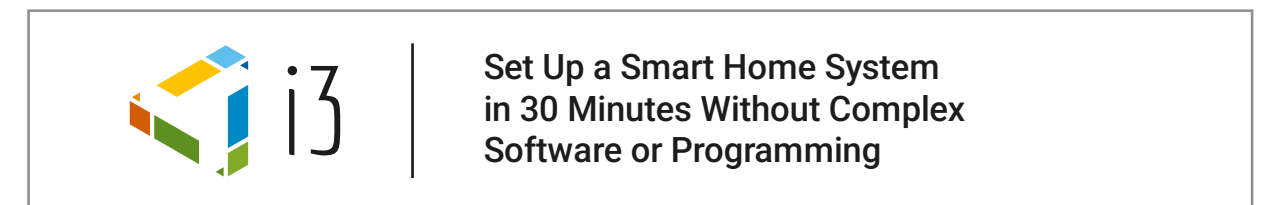
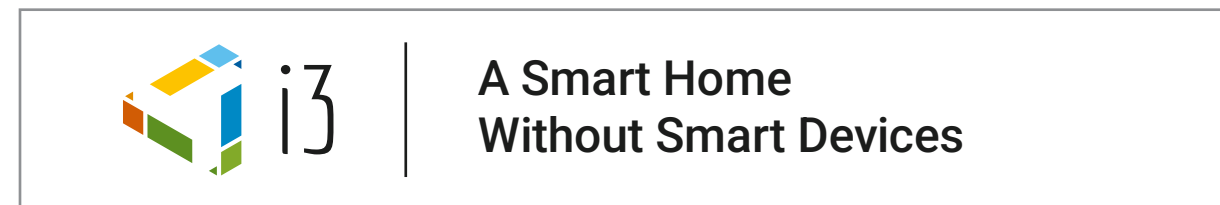
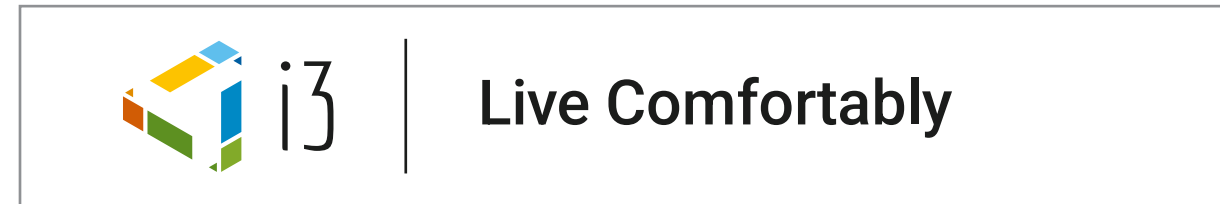

Combine the i3 logo with the partner's logo using these templates:

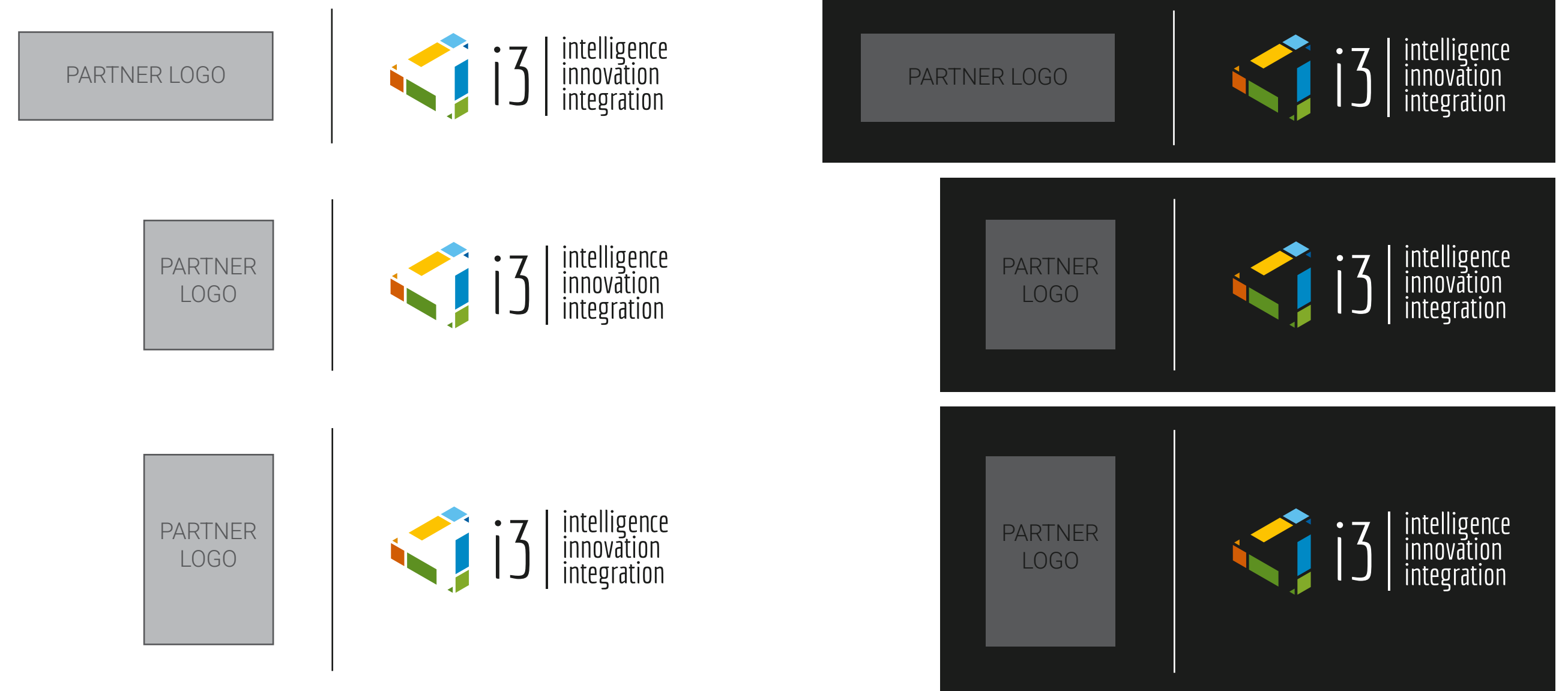



-
- Corporate font
 - Font combinations

Typography

3.0



Corporate Font

The main font of i3 is Roboto.
It uses four styles: Light, **Regular**, **Medium**, **Bold** to create successful font combinations.

Roboto

Aa, Bb, Cc, Dd, Ee, Ff, Gg, Hh, Ii, Jj, Kk, Ll, Mm, Nn, Oo, Pp, Qq, Rr, Ss, Tt, Uu, Vv, Ww, Xx, Yy, Zz
Аа, Бб, Вв, Гг, Дд, Ее, Жж, Зз, Ии, Йй, Кк, Лл, Мм, Нн, Оо, Пп, Рр, Сс, Тт, Уу, Фф, Хх, Цц, Чч, Шш, Щщ, Ёё, Ъъ, Ээ, Юю, Яя.
1 2 3 4 5 6 7 8 9 0

Heading

Roboto Bold - Used to emphasize textual headings and draw attention.

Subheading

Roboto Medium - Used for subheadings to explain and clarify the heading, ensuring a transition to the main text.

Main text

Roboto Regular - Used for brief explanations and descriptions of the main topic mentioned in the heading and subheading.

Additional text

Roboto Light - Used when necessary to create font combinations.



Font Combinations

To ensure cohesive brand identity, use the provided font combinations.

Important!

- Use only corporate fonts to emphasize the brand's visual identity.
- Use only corporate colors to maintain the brand's visual identity.
- Ensure text readability by using appropriate font size and line spacing.
- Text should be easy to read and understand. Ensure sufficient contrast between the text and the background.

Allowed Font Modifications:

Using a heading in accent orange with light gray text on a dark background.

Configure wired smart home
in 30 min or less

No programming, no laptops, no worries

Using a white heading with light gray text on a dark background.

Configure smart home
in 30 min

No programming, no laptops, no worries

Using a heading in accent blue with light gray text on a light background.

Configure wired smart home
in 30 min or less

No programming, no laptops, no worries

Using the correct font styles: Heading - **Bold**, Additional Text - Light

Configure wired smart home
in 30 min or less

No programming, no laptops, no worries

Font Combinations and Text Placement:

Smart home without smart devices	Heading: Weight: Bold
Configure wired smart home in 30 min	Subheading: Weight: Medium Size: 2/3 of the heading
No programming, no laptops, no worries	Additional Text: Weight: Light Size: 1/2 of the subheading

Smart home without smart devices	Heading: Weight: Bold
No programming, no laptops, no worries	Main Text: Weight: Regular Size: 1/2 of the heading



- Corporate font
- Corporate backgrounds
- Color modifications

Color Palette

4.0



Corporate Colors

The brand's colors are carefully selected to convey emotions, build recognition, and establish the brand's identity.

They are used in marketing materials and play an important role in color psychology. Use only our corporate color solutions in design.

The brand's colors contribute to recognition and emotional connections with clients; therefore, under no circumstances should you change the colors or deviate from them.

<p>C:0 M:48 Y:100 K:10 R:255 G:140 B:0 #E18C00</p>	<p>C:51 M:0 Y:96 K:16 R:130 G:170 B:41 #82AA29</p>	<p>C:80 M:28 Y:0 K:8 R:0 G:137 B:197 #0089C5</p>	<p>C:5 M:0 Y:0 K:100 R:27 G:28 B:27 #1B1C1B</p>
<p>C:0 M:70 Y:100 K:15 R:209 G:92 B:5 #D15C05</p>	<p>C:60 M:0 Y:100 K:30 R:93 G:144 B:33 #5D9021</p>	<p>C:100 M:50 Y:0 K:15 R:0 G:94 B:161 #005EA1</p>	<p>C:0 M:0 Y:0 K:85 R:74 G:74 B:73 #4A4A49</p>
<p>C:0 M:25 Y:100 K:0 R:253 G:195 B:0 #FDC300</p>	<p>C:35 M:0 Y:90 K:0 R:187 G:208 B:52 #BBD034</p>	<p>C:60 M:5 Y:0 K:0 R:95 G:191 B:237 #5FBFED</p>	<p>C:0 M:0 Y:0 K:30 R:184 G:186 B:188 #B8BABC</p>



Corporate Backgrounds

To diversify the graphic language of the brand, we have developed examples of corporate backgrounds. We recommend using them in design solutions when necessary.

Ensure text readability on corporate backgrounds and pay special attention to logo visibility. When using backgrounds, make sure the logo is not placed on a colored part of the background and does not blend in with it.

Important! Use color solutions specified in the brandbookforbackgrounds. Additional colors may be used only with the company's approval.





Principles for Using Accent Colors

Use accent colors when you want to create strong contrast between one element (or group of elements) and others.

It is not recommended to use multiple additional colors, as this can dilute focus and make it unclear where the emphasis is placed.

Important!

- Use only corporate fonts to emphasize the brand's visual identity.
- Use only corporate colors to maintain the brand's visual identity.

Combination of a **dark background** with the accent color - **orange**.

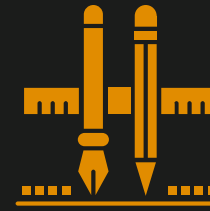

Designing

Filling out i3 Check list: getting technical details and selection of the system functionality in accordance with the wishes of the customer. Selection of controllers and peripheral devices. Approval of the estimate.

Combination of a **white background** with the accent color - **blue**.

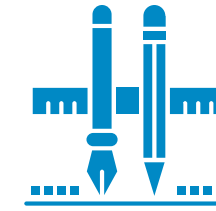

Designing

Filling out i3 Check list: getting technical details and selection of the system functionality in accordance with the wishes of the customer. Selection of controllers and peripheral devices. Approval of the estimate.



- Brand icons

Corporate Icons of the Company









50



Brand icons

We have developed a set of icons for our brand. Use them in design.

If new icons need to be created, adhere to the style of existing icons. Ensure the readability of all graphic elements in the icons.

	LIGHTING		BACKYARD
	HVAC		MULTIMEDIA
	SAFETY & SECURITY		ENERGY SAVING
	BLINDS & ROLLERS		CAMERAS



-
- Device images
 - Device proportions

Devices and Their Proportions

6.0



Device images

To ensure better readability of devices, it is better to place their images against a dark gray background, as shown in the examples. Use only corporate gray colors for the background. Any other design decisions for device images must be coordinated with i3 managers.

Important! Never change the proportions of the devices. For all necessary materials regarding devices, contact i3 managers.

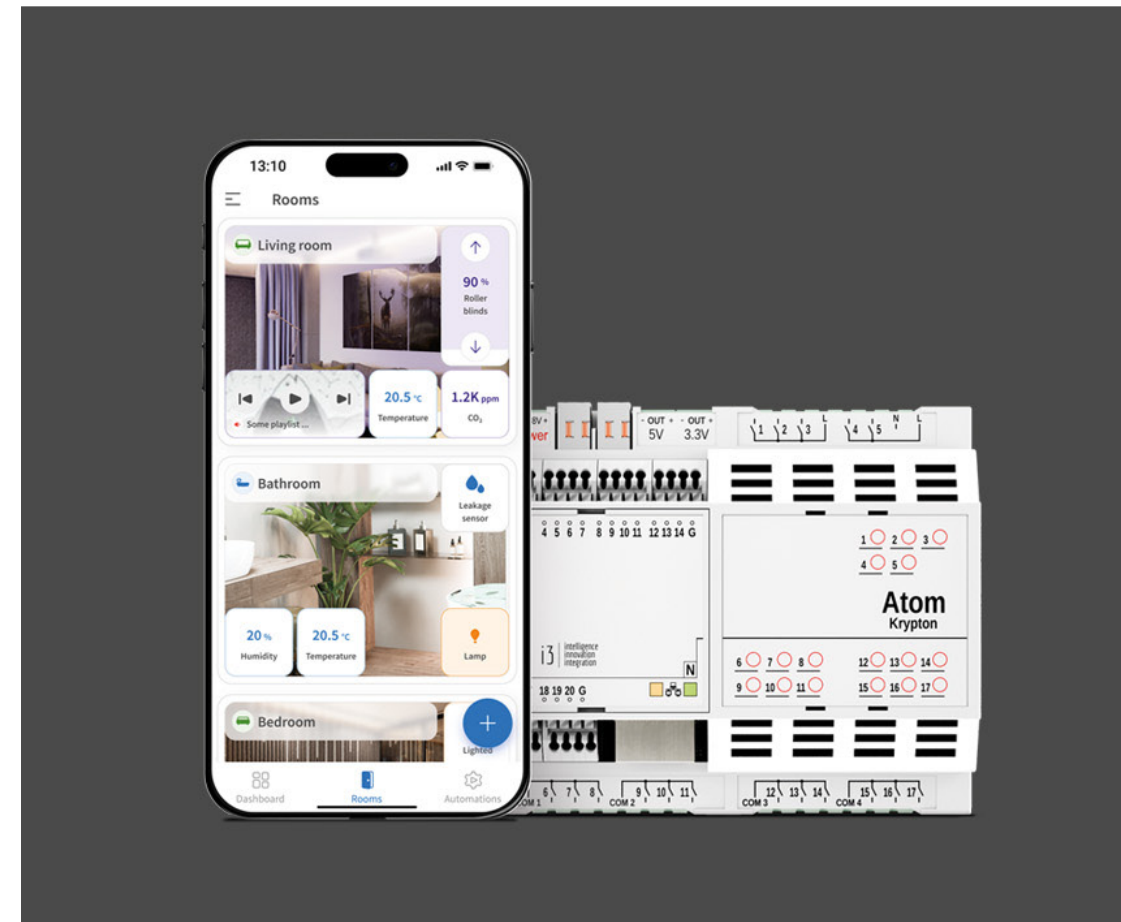
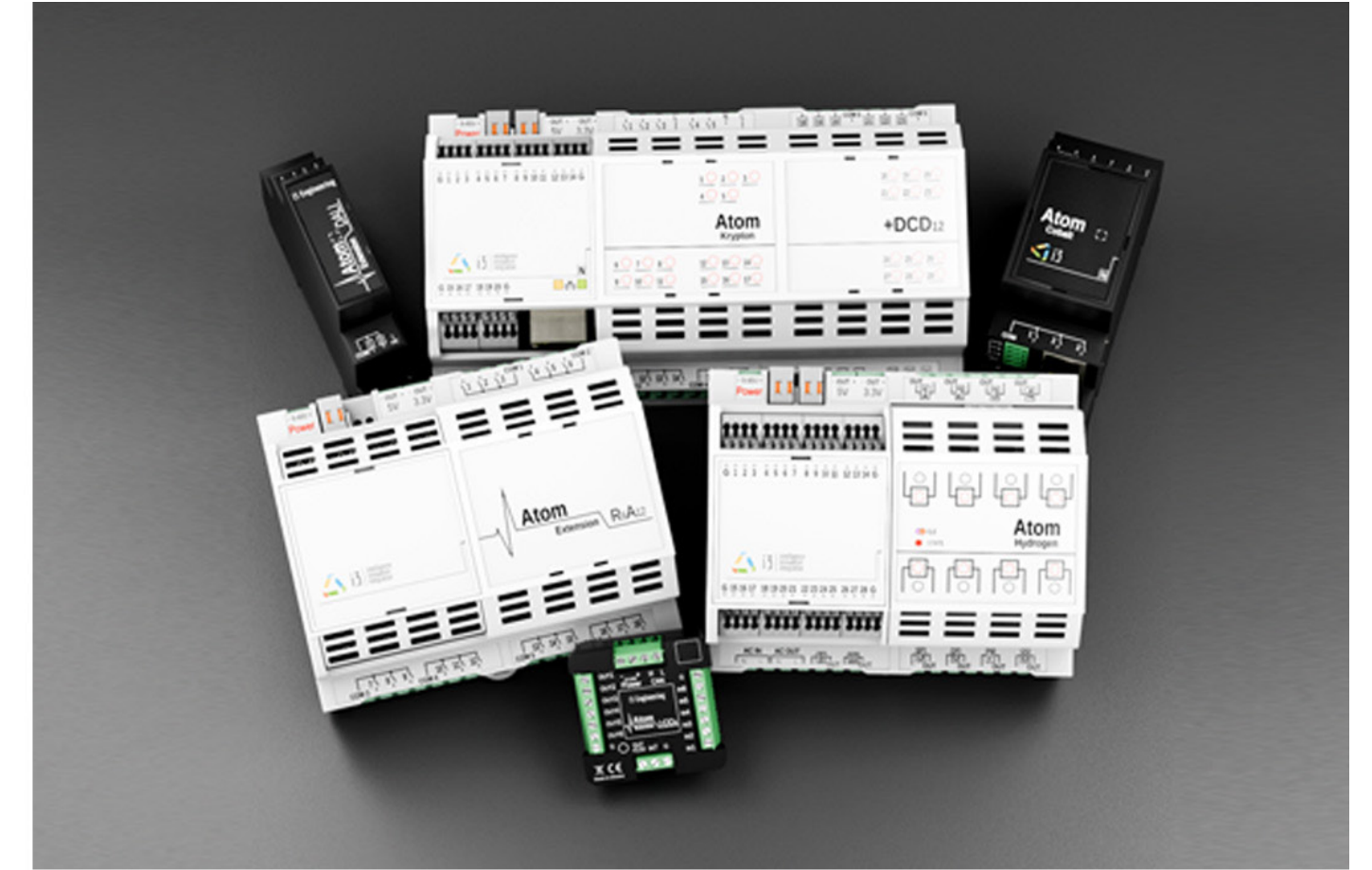
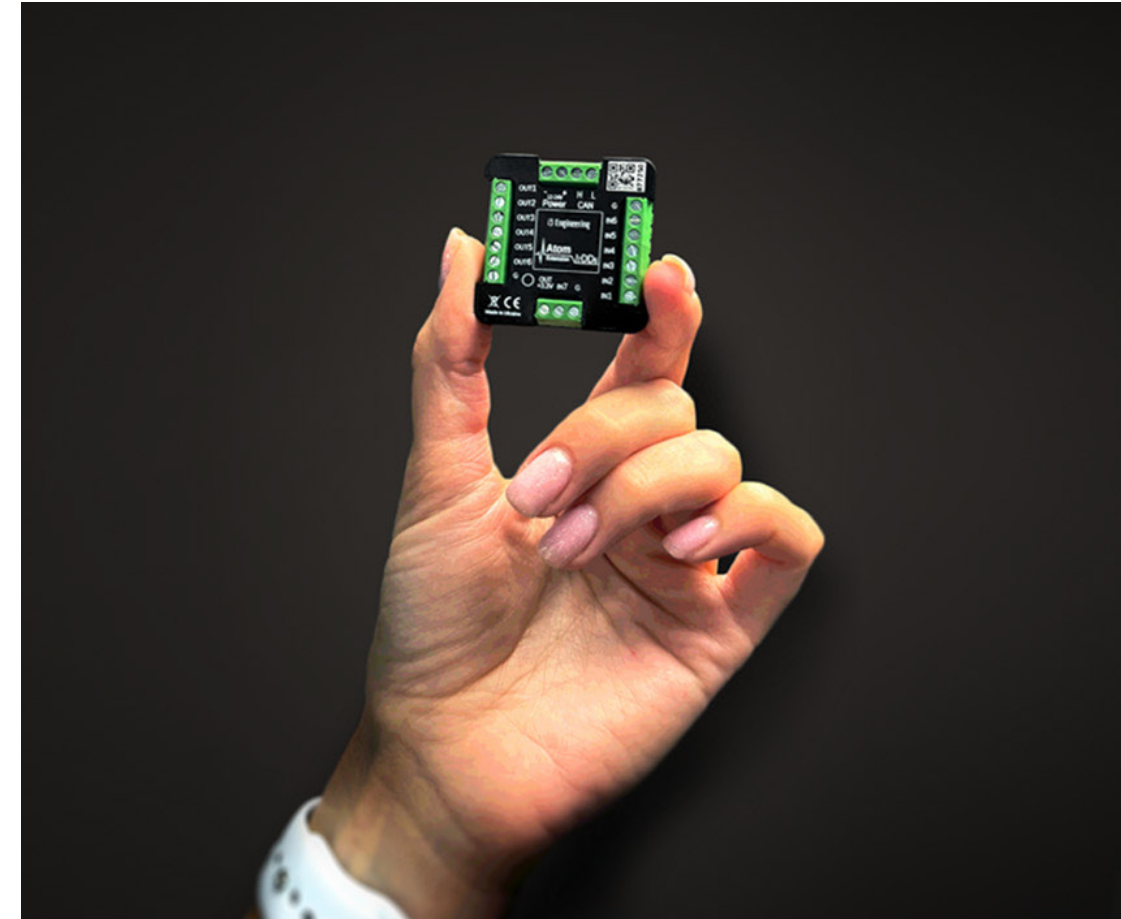



Device proportions

The proportions of the devices and the principles of their relationships are shown in the image.

It is important to adhere to the given proportions of devices and never change them..

Atom series controllers

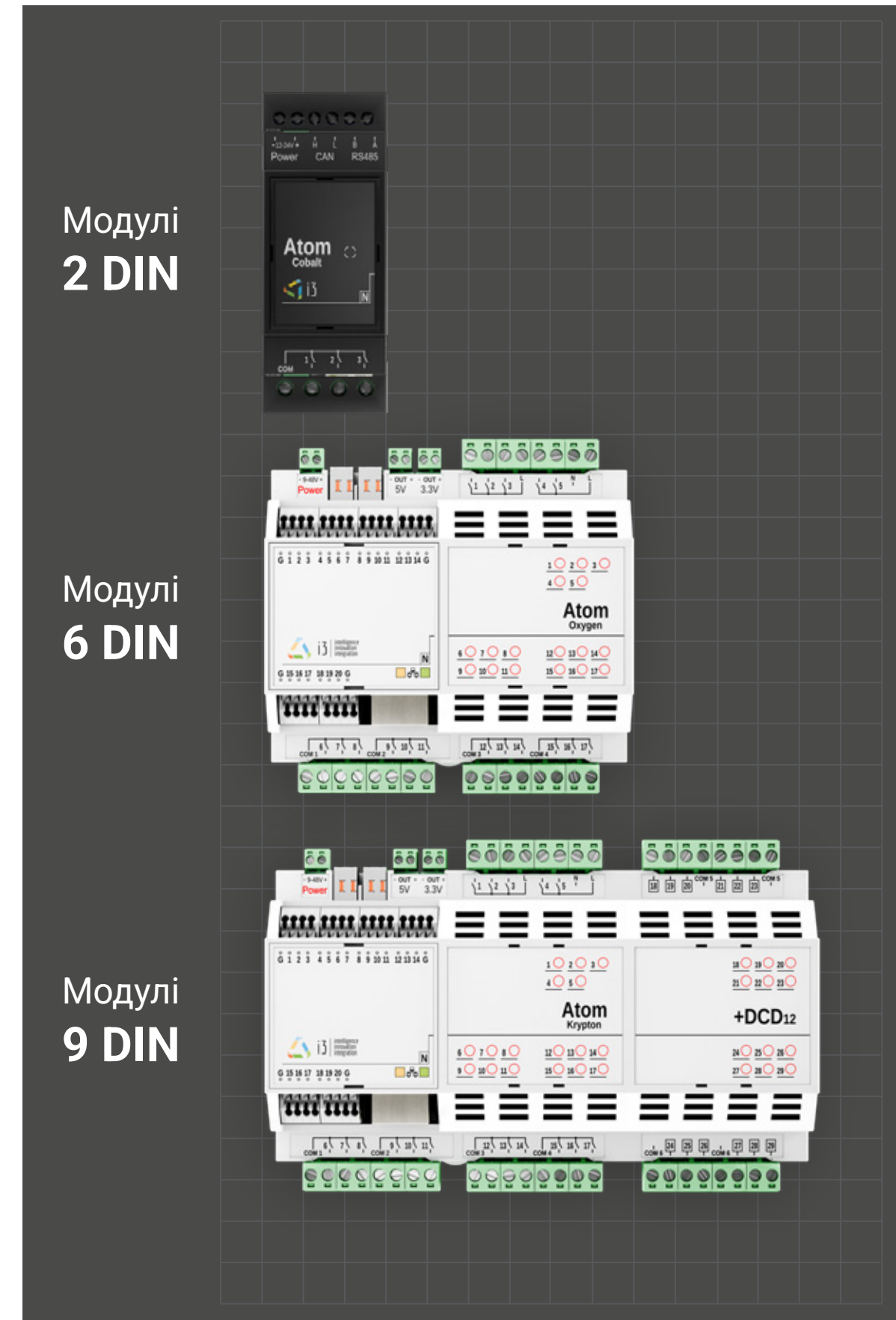

Atom Extension series controllers

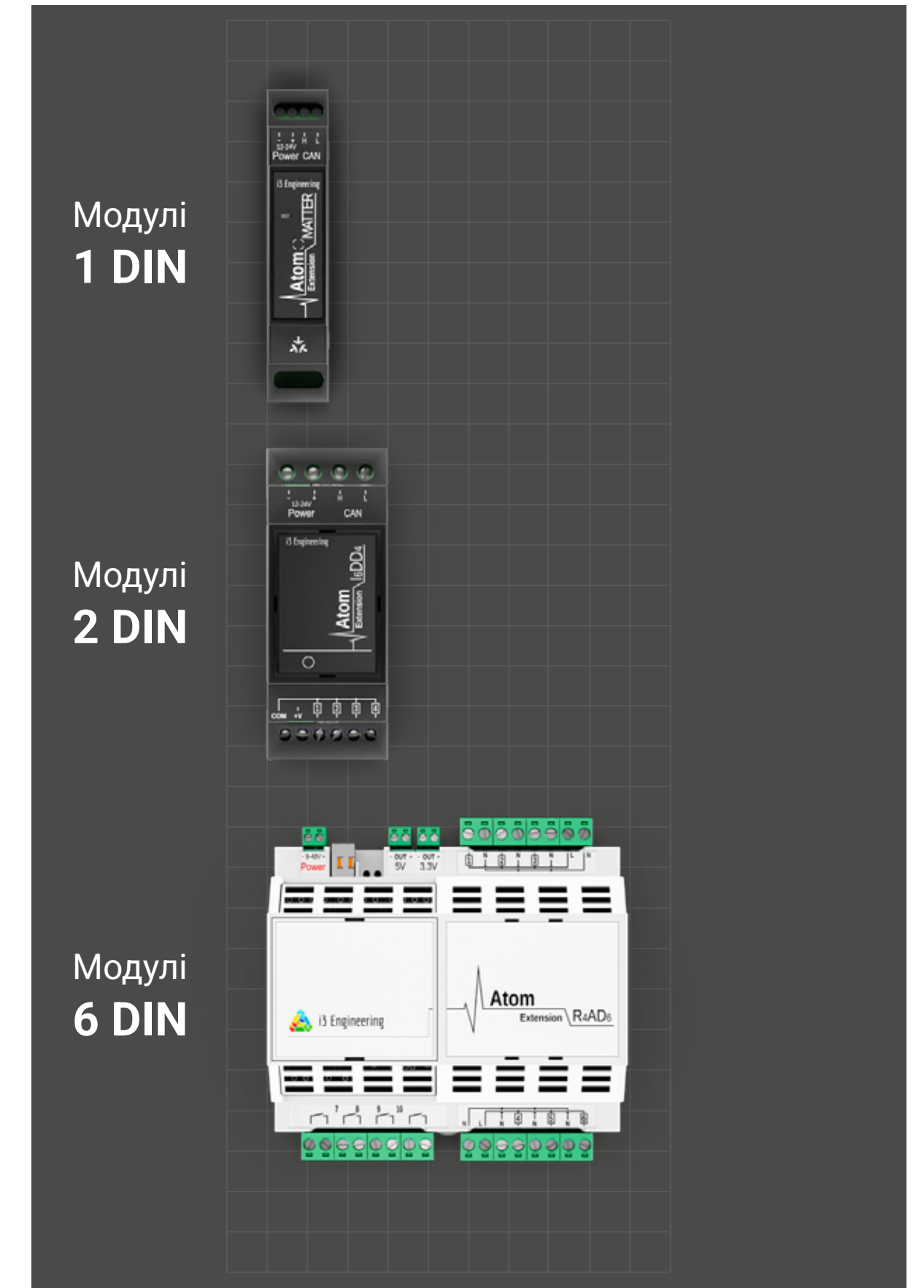



-
- Business card and letterhead
 - Souvenir products
 - Vehicle branding

Corporate Identity Materials

70



Business card and letterhead

Consistent placement of the logo and text on all business cards and letterheads is crucial to maintaining a unified brand image.

This approach guarantees brand recognition and highlights the professionalism of all design elements.

Important! to adhere to the approved design of business documents and never alter them.

Letterhead

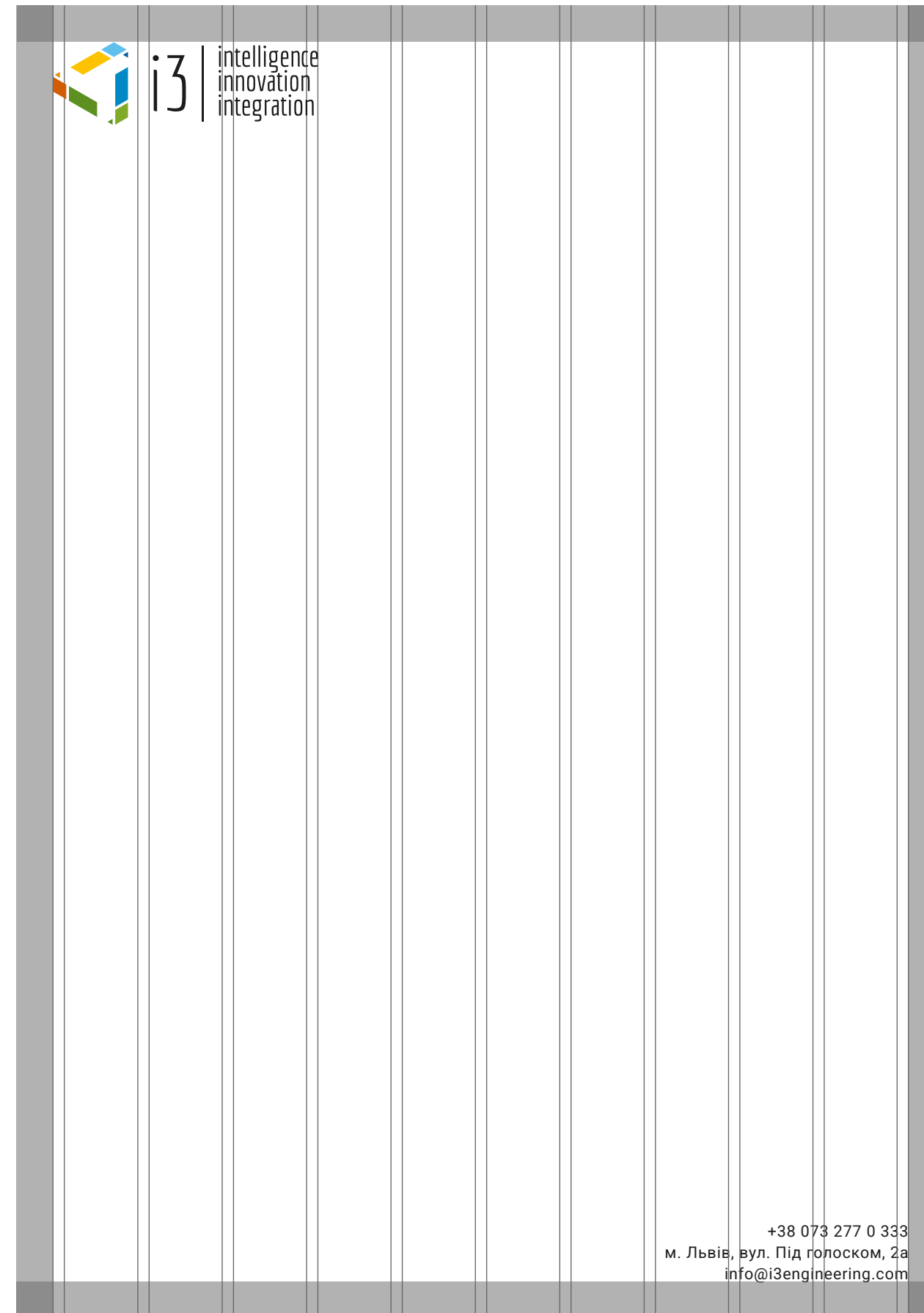

Business card





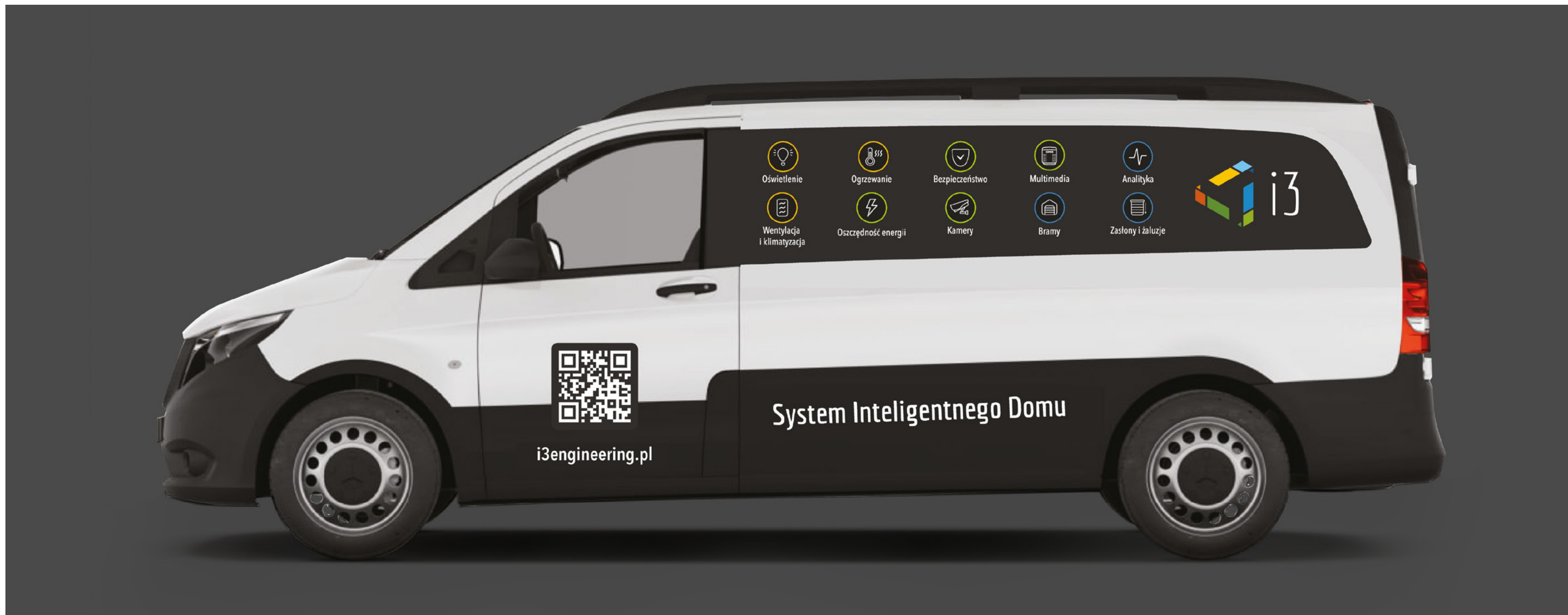

Thank you

for adhering to the rules
for using the corporate style.